

Checkmatic Universal Bench Fixture

The **Bowers Checkmatic** is a universal comparator gauge with a built in multifunction digital display. This versatile gauge can be configured in a multitude of ways, facilitating the rapid, accurate, internal or external gauging of both simple and complex components. A comprehensive range of accessories is available for the Bowers Checkmatic, alternatively special accessories can be designed for more specialised applications.

WiFi

RS232

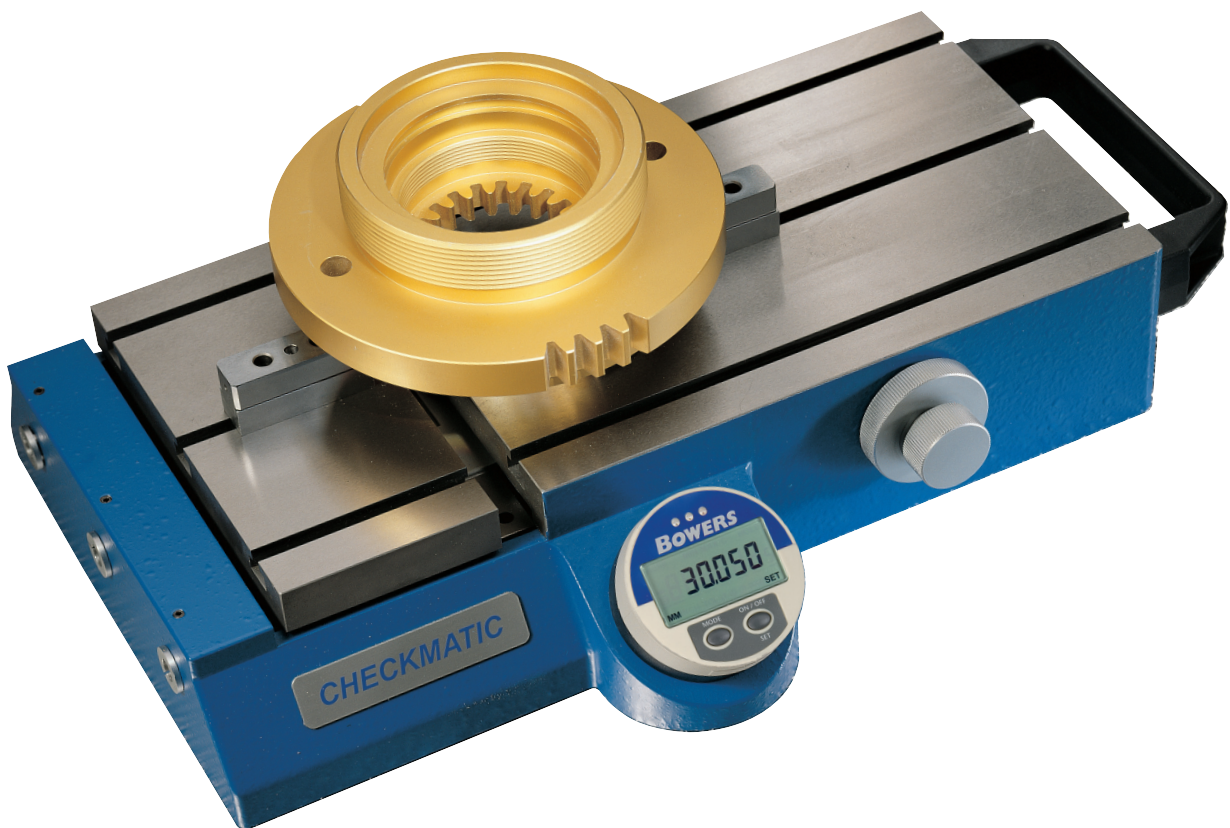

Features:

- Optional integral electronics
- 0.01/0.001mm (0.0005"/0.00005") switchable resolution
- Inch – Metric conversion
- Preset
- Preset recall
- Zero settings
- Memory hold
- Ref 1 & Ref 2 memories
- Min/Max
- Tolerance input
- RS-232 output
- 1 year battery life
- Three T-slots for mounting measuring accessories and contacts
- Nominal 15mm table travel
- Reversible measuring force
- Variable measuring force 7-9n
- Robust construction
- Central float position
- Caged ball technology



Checkmatic Universal Bench Fixture

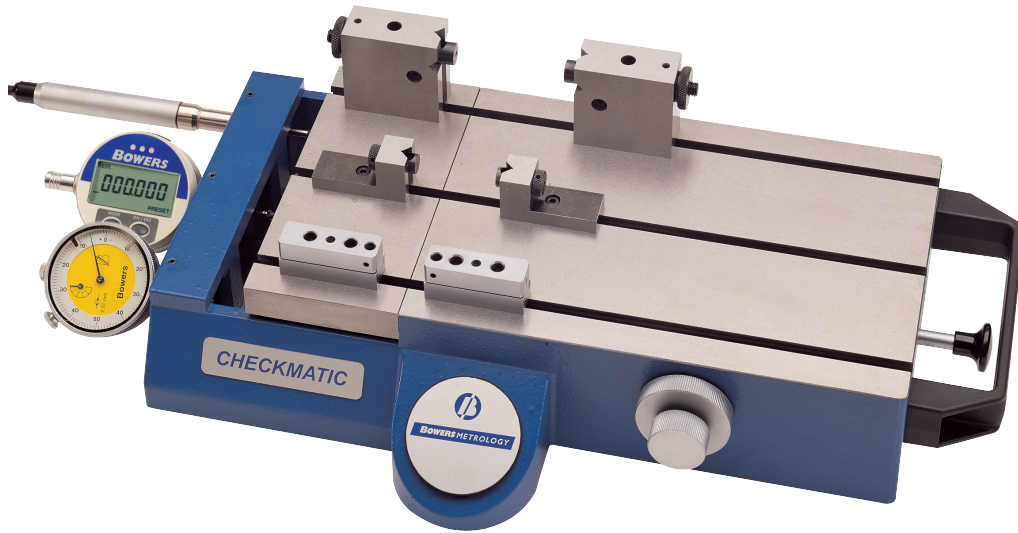

APPLICATIONS

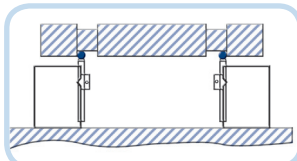

Bearing Face Distance

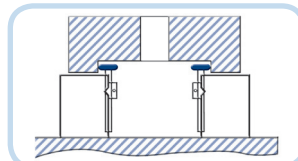

Internal Diameters

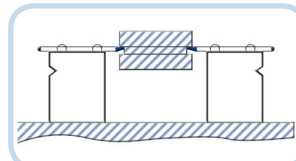

External Diameters

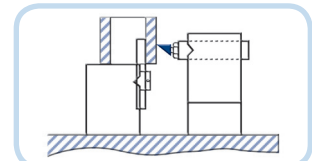

Concentricity/Wall Thickness

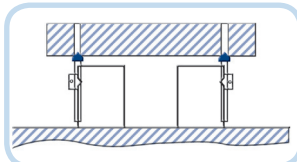

External Splines

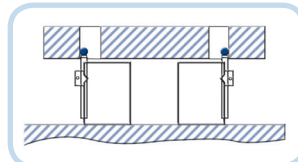

Hole Position

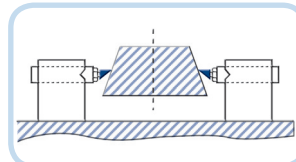

External Tapers

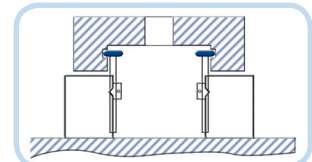

Internal Recess Diameter

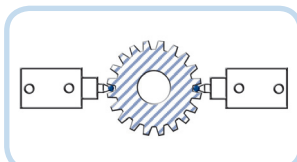

External Splines

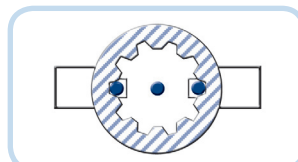

Internal Splines

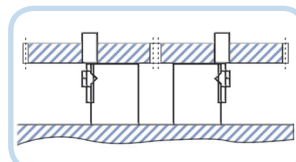

Roller-gear Measurement

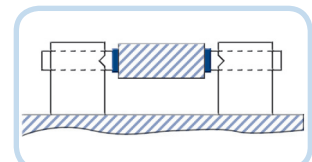

Length Measurement

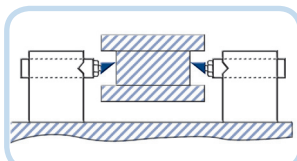

Recess Diameters

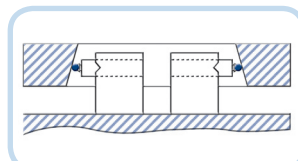

Internal Tapers

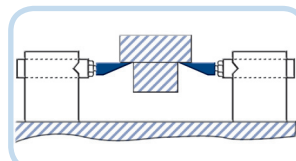

Rolling Gear Test

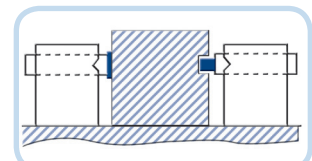

Slot Depth

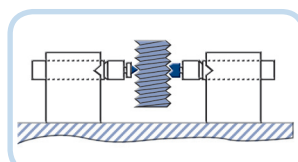

Thread Measurement

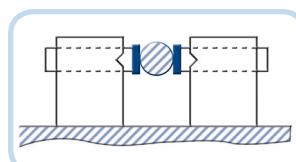

External Diameters (Round Parts)

Checkmatic Universal Bench Fixture

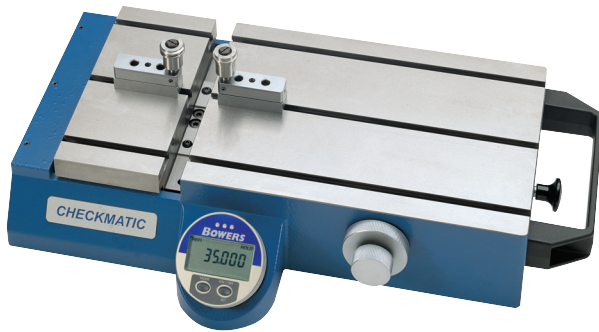

Thread Rolls



Internal/External Grooves

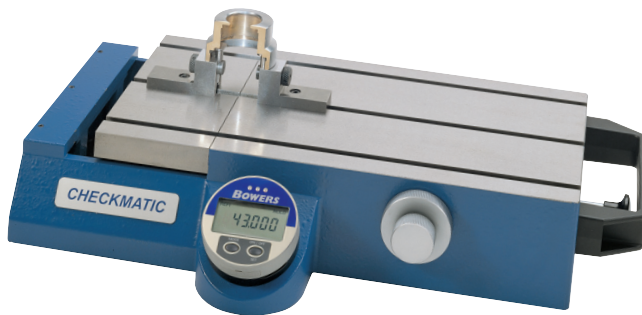

Internal/External Diameters



Centre Axis Distance (Max-Min)

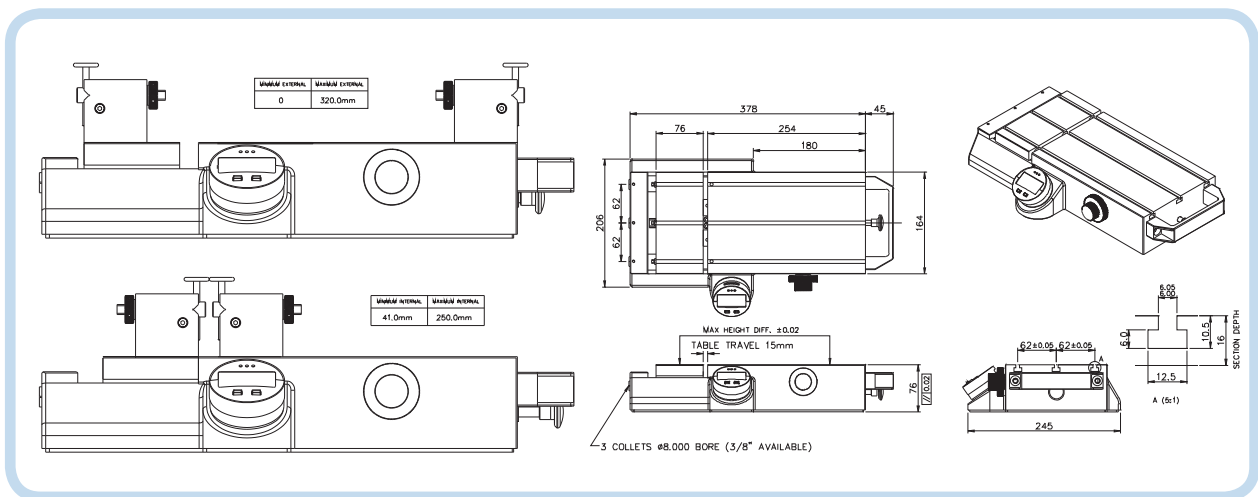



Checkmatic Universal Bench Fixture

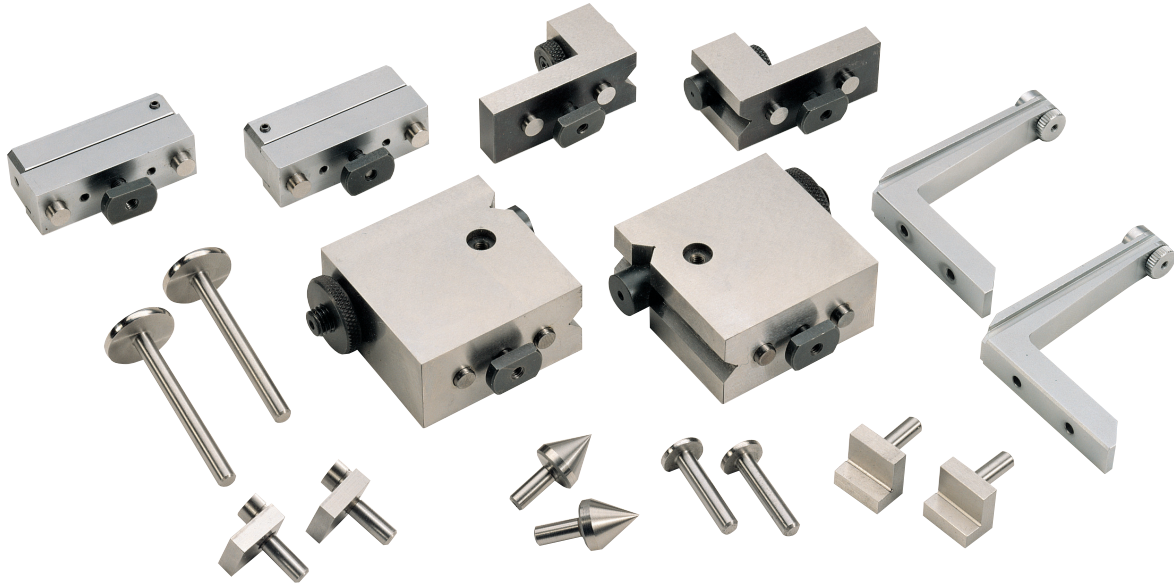

Tooling and accessories not included with Checkmatic basic gauge

CKUA005

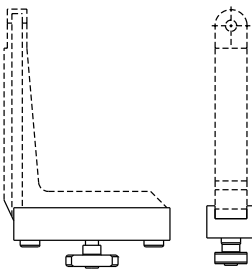

Universal gauge
Tooling Adapter Arm

CKTB003

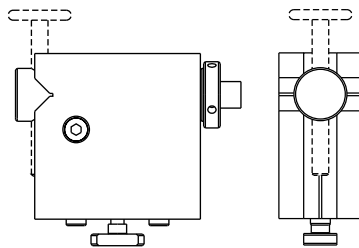

Large Tooling Block

CKTB004

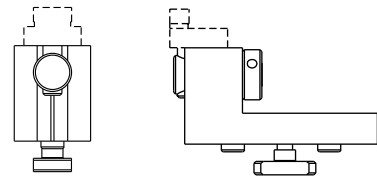

Small Tooling Block

PRODUCT CODES

CHECK001	Checkmatic with digital indicator
CHECK002	Checkmatic without indicator
CKTB003	Large tooling blocks (pair)
CKTB004	Small tooling blocks (pair)
CKUA005*	Universal Gauge tooling adapters (pair)

TGUA006	Measuring arms 50mm
TGUA007	Measuring arms 75mm
TGUA008	Measuring arms 100mm

*Note: The **CKUA005** Universal Gauge tooling adapters will be necessary to use the following accessories